



Upgrade of the Fast Beam Conditions Monitor BCM1F

Roberval Walsh, DESY, for the CMS BRM Group
CMS Upgrade Week, Hamburg, 3 – 7 June 2013



Introduction

The BCM1F detector is one of the subsystems of the CMS Beam Conditions and Radiation Monitoring (BRM) system. Designed to monitor the flux of particles with a time resolution of a nanosecond, BCM1F is able to fast diagnose adverse beam conditions, such as beam losses, that could be harmful for the detector components. **It monitors luminosity as well as vacuum and beam-background conditions at real time in the region close to the CMS pixel detector.**

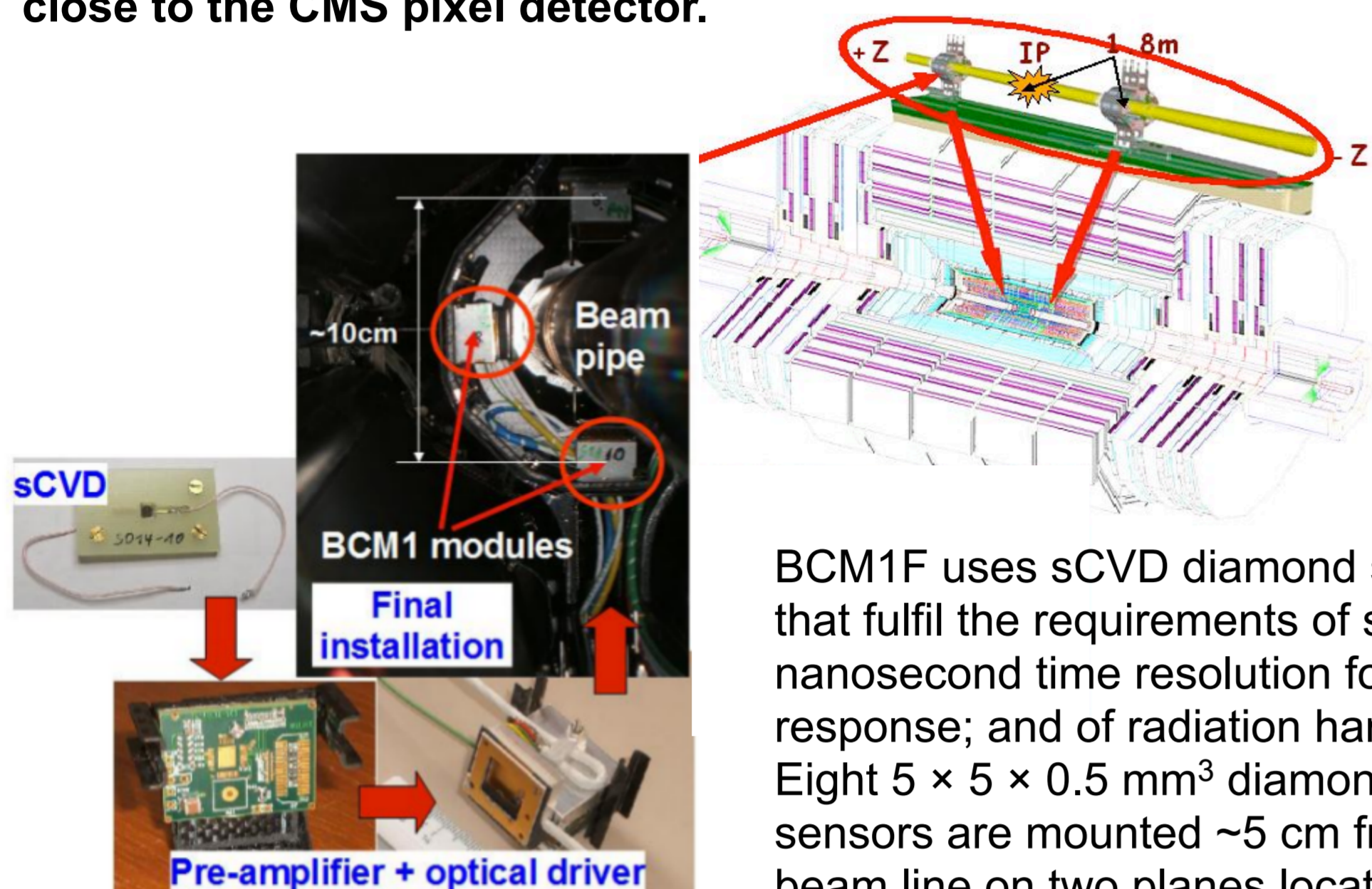

Fig. 1: Schematic showing the location of BCM1F. The pictures show the sensors and front-end before and after installation.

BCM1F uses sCVD diamond sensors that fulfill the requirements of size, of nanosecond time resolution for fast response; and of radiation hardness. Eight $5 \times 5 \times 0.5 \text{ mm}^3$ diamond sensors are mounted $\sim 5 \text{ cm}$ from the beam line on two planes located on both sides and $\sim 1.83 \text{ m}$ away from the CMS interaction point (Fig. 1), which is an optimal location for separation of incoming and outgoing particles.

BCM1F was installed in 2008 and in operation since then until 2013.

Data acquisition system in 2012

In each module, a sensor is connected to a radiation hard front-end ASIC. The signals are pre-amplified, shaped, converted into analog optical signals and transmitted to a CMS service room where they are converted back to electrical signals, then discriminated, digitised and processed. Information on hit rates, coincidences, signal shape and time over an orbit are provided by a system made up of scalars, a look-up table (LUT), a flash analogue-to-digital converter (ADC) board and a time-to-digital converter (TDC) board. The BCM1F chain is illustrated in Fig. 2.

BPTX signals are used to produce gates, with time windows, to measure: the rate of collision products for luminosity measurement; the non-colliding bunches beam-halo rate for vacuum conditions; and rates halfway between two collisions to estimate the albedo contributions.

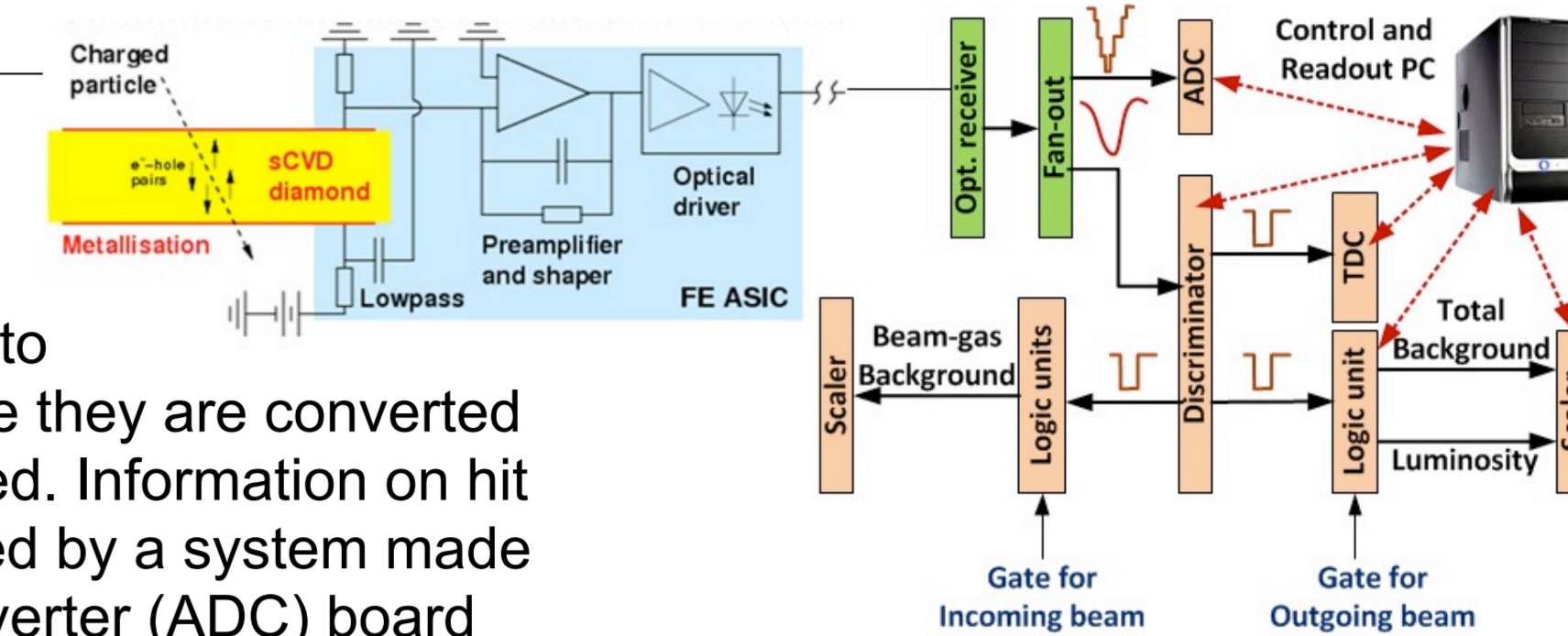

Fig. 2: Schematic layout of the BCM1F electronics architecture as in 2012.

BCM1F performance with data

Beam background measurements

BCM1F delivers to the control rooms two background numbers to ensure safe CMS & LHC operation: the total flux of particles in the inner region of the pixel detector and the Flux of particles due to beam interaction with residual gas atoms in the beam pipe and the collimators.

Luminosity measurements

The relative online luminosity is measured using the zero-counting method from the rate of events when there is a hit in at least one diamond in the collision gate window.

The visible cross section has been measured on special LHC runs using the Van der Meer (VdM) scan technique to perform an absolute calibration of the luminosity. A measurement of the mean overlap and the effective size of the x-component of the beam is shown in Fig. 3. Fig. 4 shows the measurement of the instantaneous luminosity with BCM1F during an LHC fill after calibration and corrections for inefficiencies. For comparison the HF luminosity is also shown.

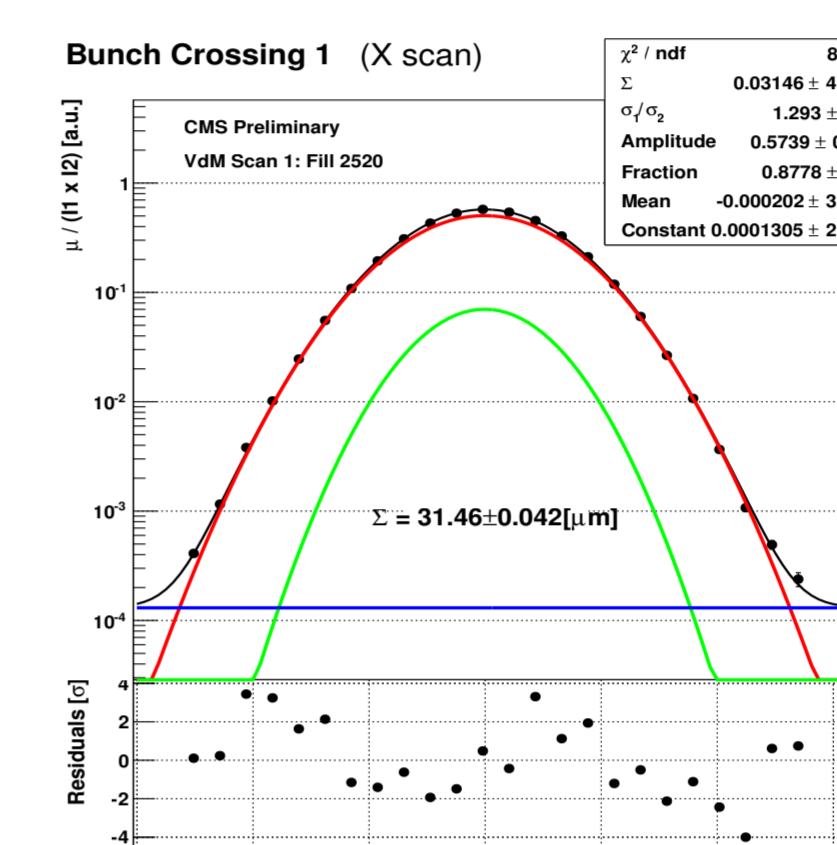

Fig. 3: Measurement of the x-component of the beam during a VdM scan in 2012.

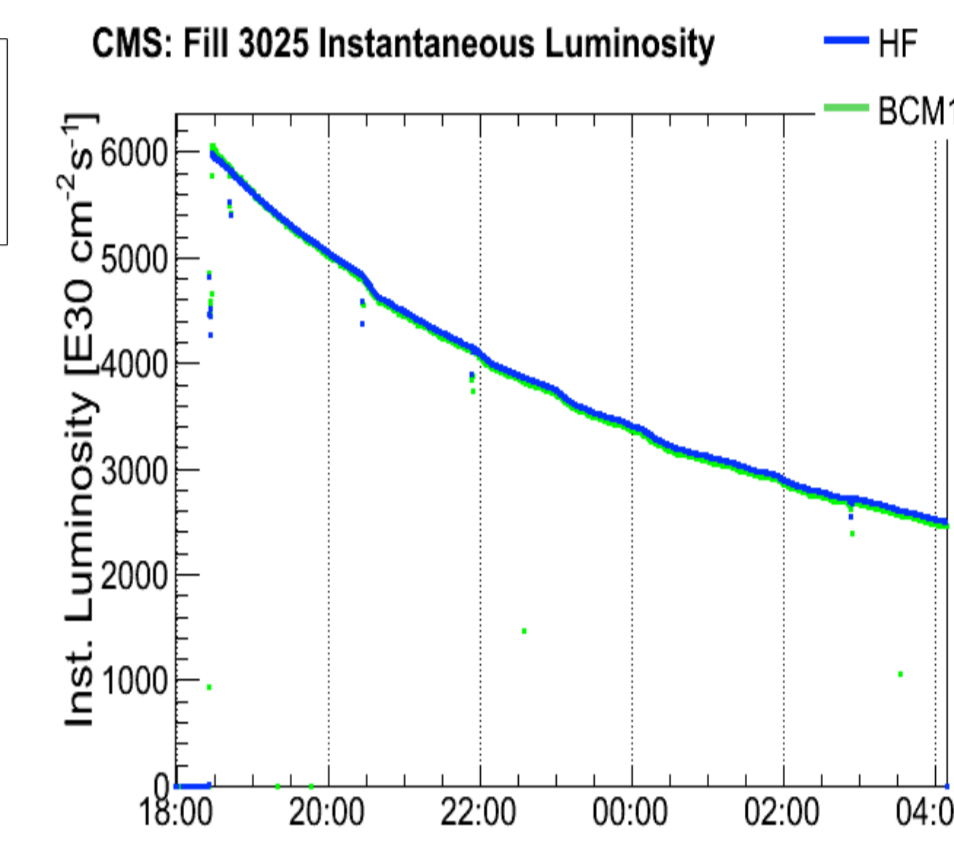

Fig. 4: BCM1F luminosity measurement compared to the HF detector.

BCM1F Upgrade Motivation and Plans

After the LS1 the LHC will operate at higher luminosity, of at least $10^{34} \text{ cm}^{-2}\text{s}^{-1}$, and at higher energy, 6.5 TeV per beam. Moreover, the time between two bunch crossings will decrease from 50 ns to 25 ns. The current BCM1F system has limited performance under these conditions. A new system with improved time resolution and better multiple-hit detection is under development and to be operational in 2015.

The upgraded system envisage new front-end and back-end with characteristics that should strongly attenuate the sources of inefficiencies and give more precise information on conditions that can affect the efficiency and gain. An example of inefficiency is shown in Fig. 5. The efficiency losses observed within each bunch train has been identified as due to the saturation of the preamplifier leading to long dead-times (Fig. 6).

The gain in signal has shown to be dependent on the temperature of the laser, it is also foreseen a cooling system and temperature monitoring of the lasers. A new carriage with such services integrated is under development. The gain will be monitored injecting pulses during the abort gap.

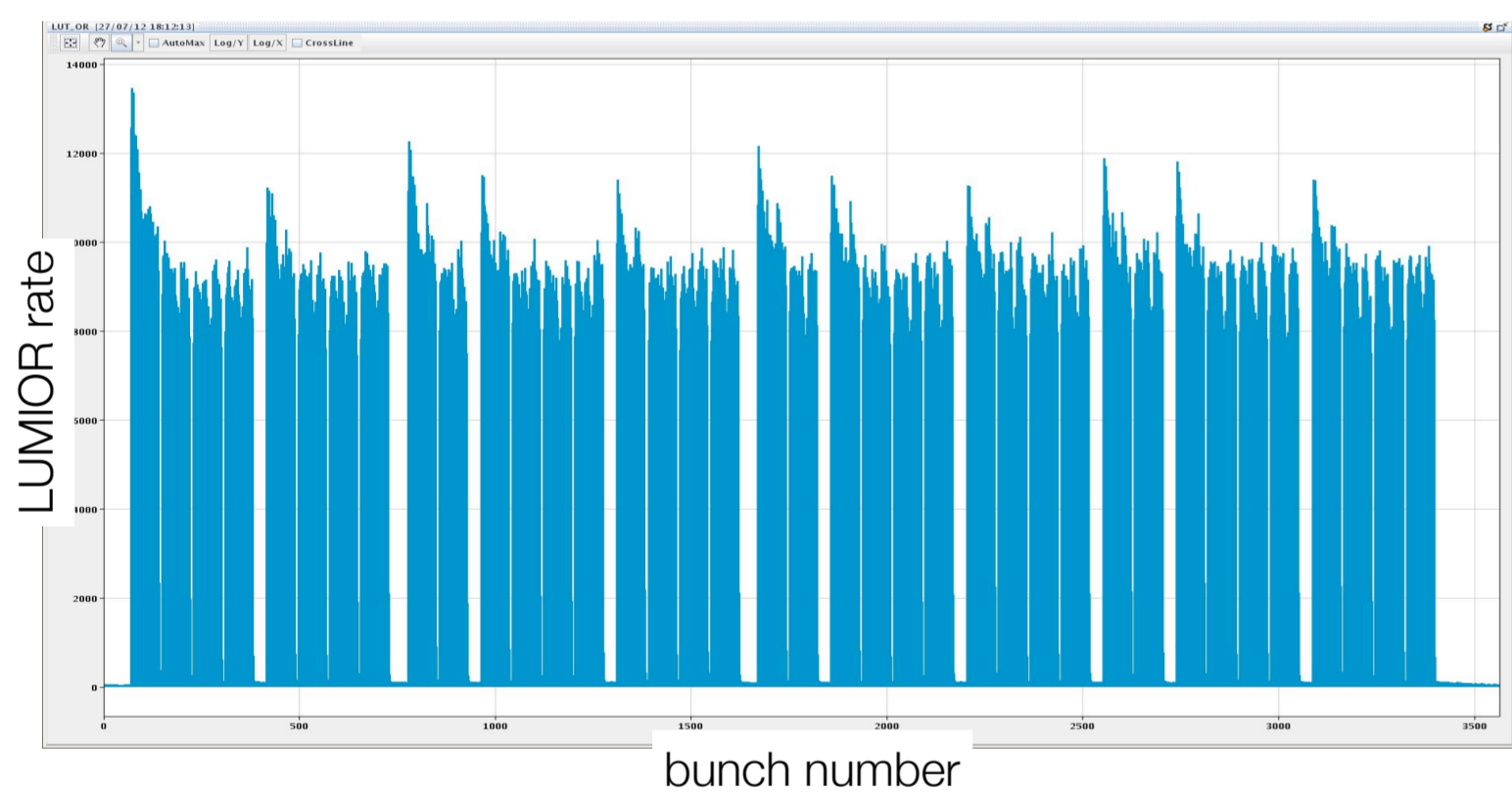

Fig. 5: BCM1F LumiOR rates as a function of the LHC bunch number.

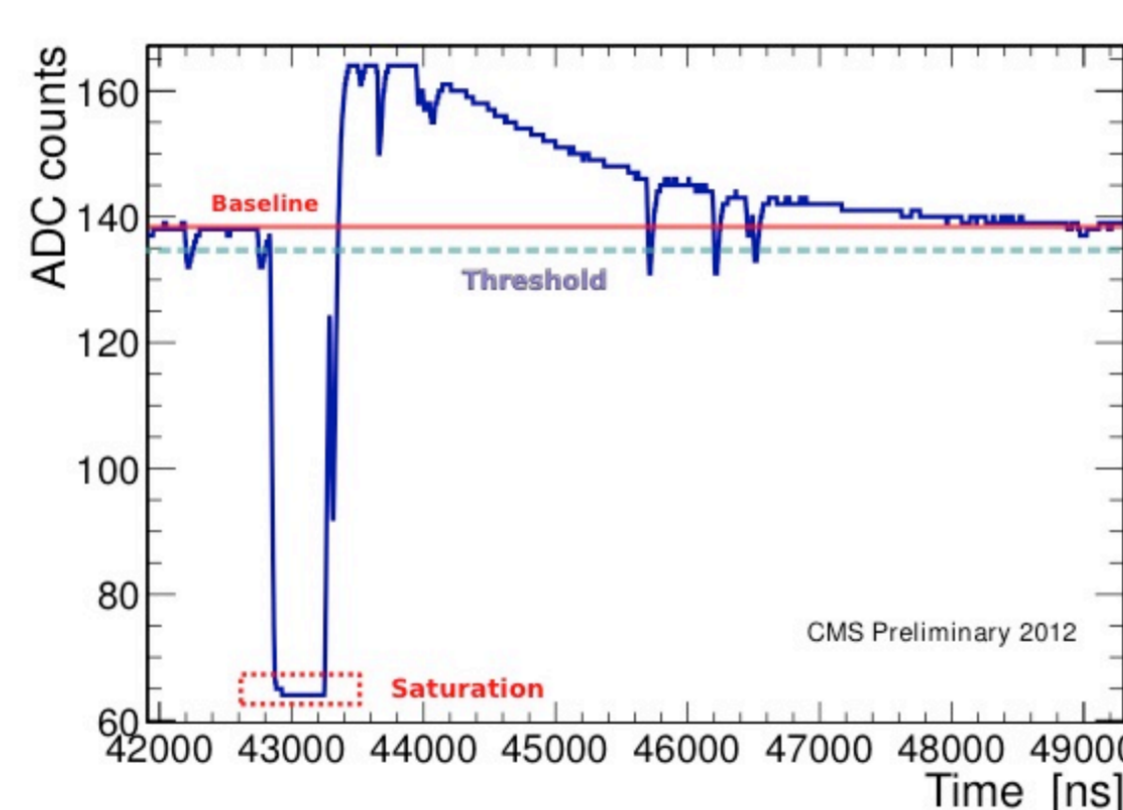

Fig. 6: Overshoot pulse due to the saturation of the front-end.

New front-end ASIC

A new fast and radiation-hard front-end ASIC has been developed by Dominik Przyborowski, UST Kraków. It features a factor 3 increase in signal gain, allowing good signal-noise separation; a signal peaking time (t_p) and full width at half maximum (FWHM) of less than 10 ns (Fig. 7a) will permit good resolution of consecutive collisions at 25 ns bunch space; capability to distinguish consecutive signals with separation of 12 ns (Fig. 7b); and shorter response for large pulses (Fig. 7c), which will reduce deadtime. In fact, the pre-amplifier saturation should be mitigated by an active baseline recovery and a rollover of the gain to avoid saturation of the pre-amplifier implemented in the new front-end.

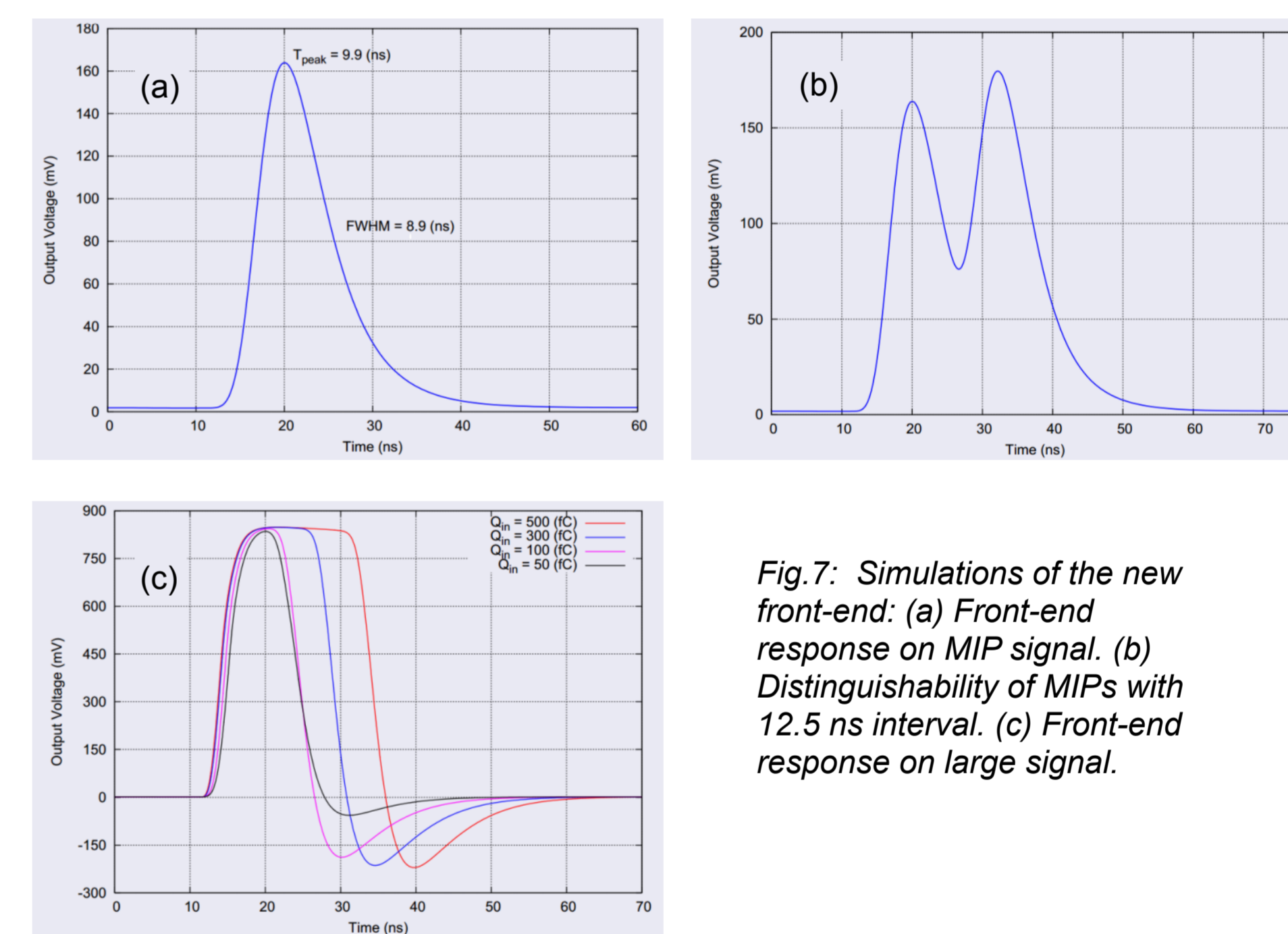
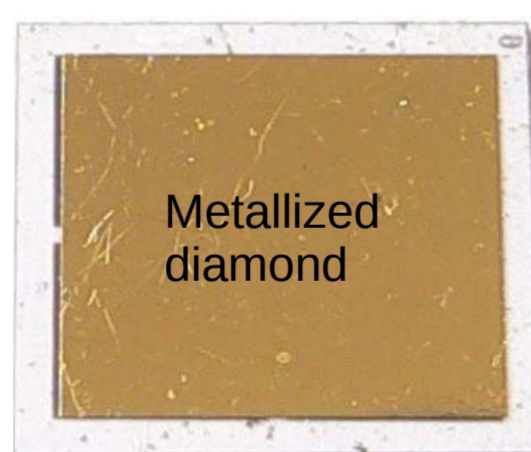

Fig. 7: Simulations of the new front-end: (a) Front-end response on MIP signal. (b) Distinguishability of MIPs with 12.5 ns interval. (c) Front-end response on large signal.

New sensors

The number of diamond sensors will increase from 8 to 24, giving a higher degree of redundancy. Each diamond will be split in two pads to suppress the multiple hit rate at high pile-up.



New back-end electronics

The expected very high rates after the LS1 and the requirement of count rate measurement with minimal deadtime and pile-up losses need a dedicated backend equipment. The system should identify hits and their arrival time with respect to the LHC orbit trigger. An automatic calibration system is envisaged. Other main features are described below.

Multiple Gate and Delay (MGD)

MGD units will be used for counting rates of collisions, beam-gas and albedo events in gated time windows. The albedo will become more important and should be done online. The logics for beam-gas should be revised as no non-colliding bunches is foreseen.

Histogram Unit (RHU)

A real time histogramming unit (RHU) board is under development and will allow the measurement of bunch-by-bunch luminosity online and possibly for postmortem analysis. The first units produced were tested and validated in 2012 with LHC p-Pb collisions (Fig. 8). Further developments on hardware and firmware are ongoing to be fully integrated in the CMS Lumi DAQ system.

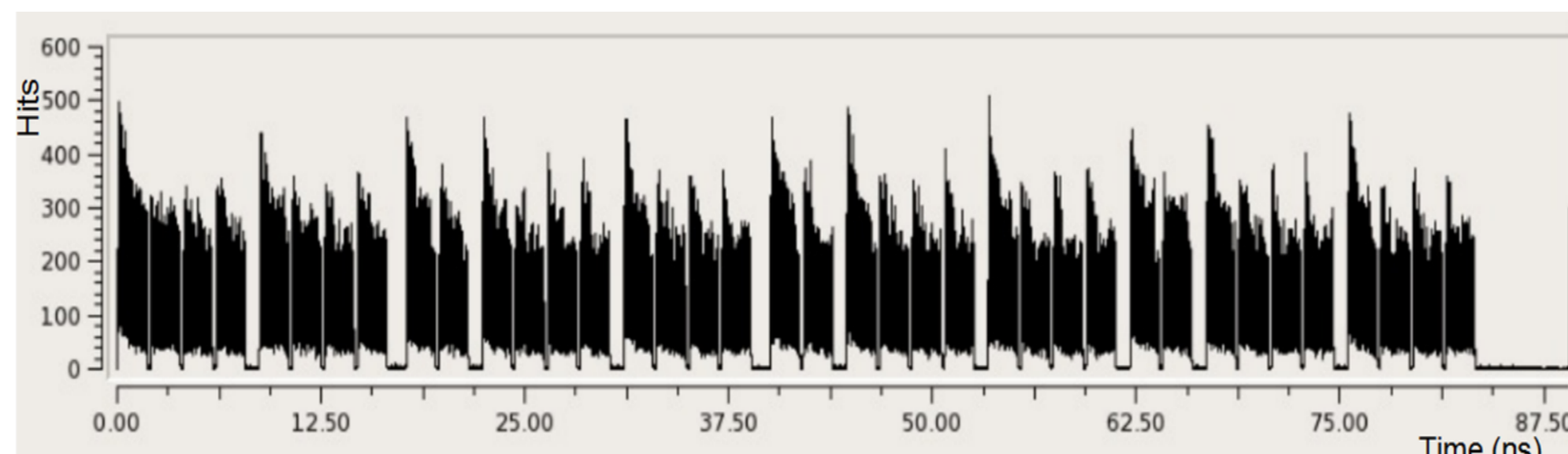

Fig. 8: BCM1F raw hits distribution as a function of the arrival time with RHU.

FPGA-based back-end

The use of modern digitisers with built-in FPGA capabilities is under study as a more suitable solution for the expected running conditions during the LHC Run II. Peak finders and deconvolution (Fig. 9) algorithms programmed in the FPGA could give, without deadtime, better distinguishability between signals with small separations, very good time resolution and reduced data size.

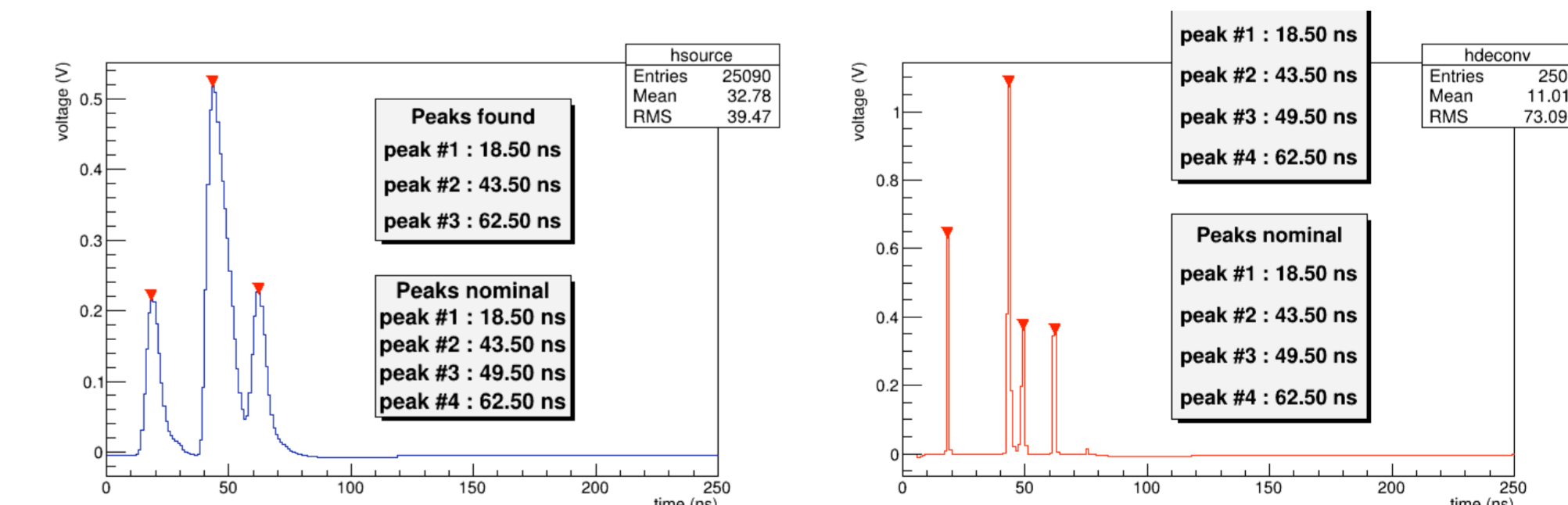
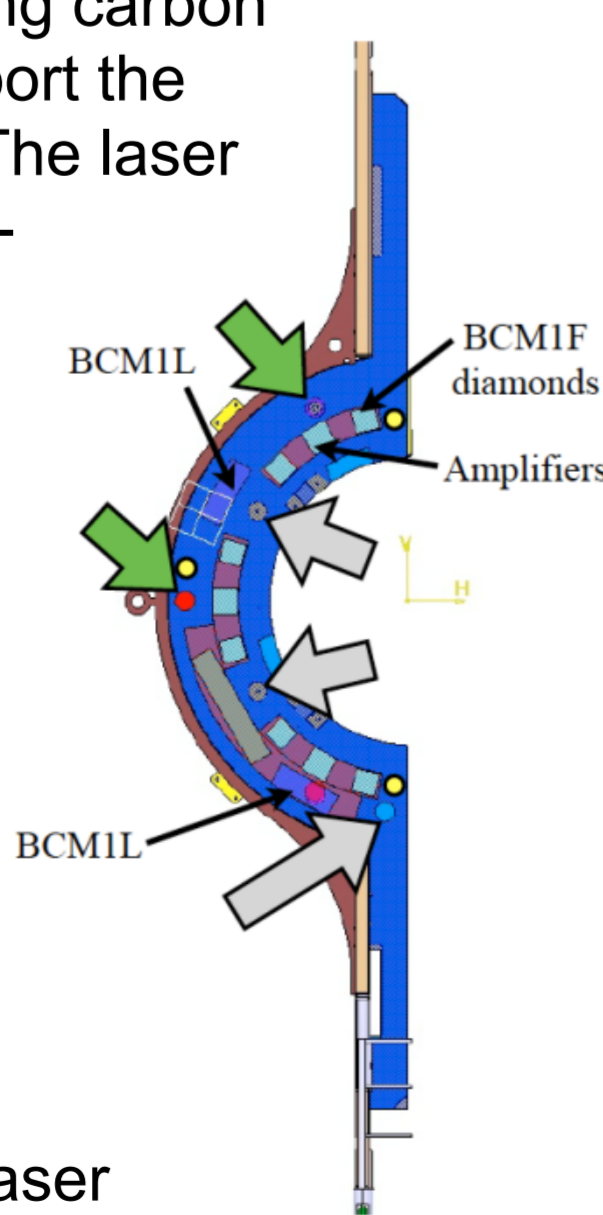

Fig. 9: Non-FPGA example: (Left) New front-end simulated signals from the ADC searched using Root peak finder algorithm. (Right) The same signals after Root deconvolution and peak finder algorithms.

New carriage

A new mechanical structure using carbon fibre is being developed to support the diamonds, ASIC and services. The laser drivers will be moved to a lower-radiation part of the carriage to avoid radiation damage. Four integrated C-shape PCB are planned, each with:

- 6 BCM1F diamonds (each split in two channels)
- 2 BCM1L diamonds
- Temperature monitoring
- Integrated cooling for the lasers
- Integrated transport to linear laser drivers and analog opto-hybrids.



Simulations

In order to shape the architecture of the back-end electronics as well as understand better the sources of systematics, BCM1F is being integrated in the CMS geometry to use simulated minimum bias events with pile-up for studies of rates, efficiencies, linearity etc.

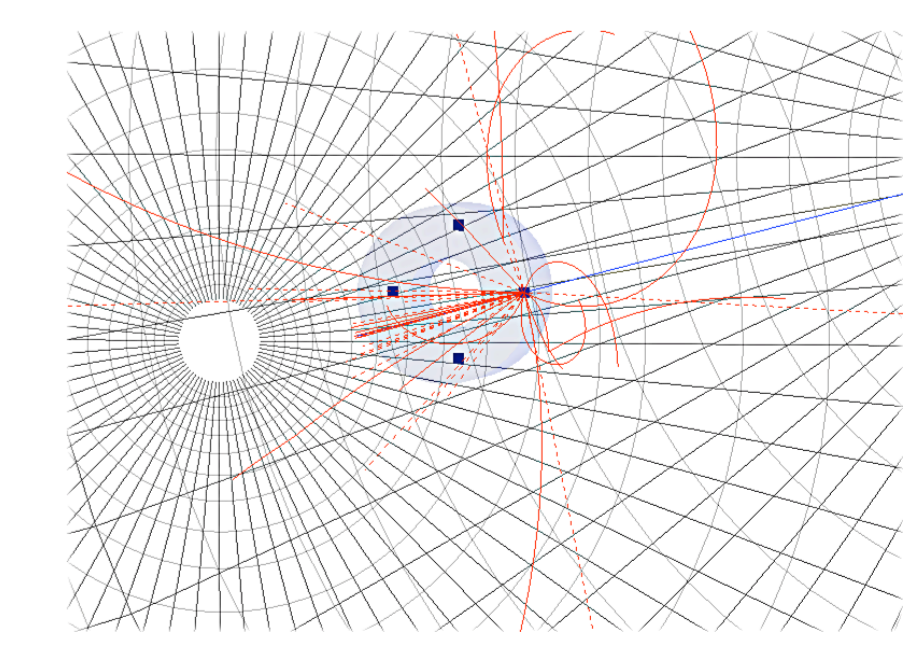

Fig. 10: A simulated 20 GeV proton hits one of the BCM1F sensors

Outlook

The BCM1F detector has proven to be a robust and reliable beam-background and online luminosity monitor with underlying characteristics to cope with significant increases of the luminosity. However an upgrade of the system is mandatory not only to cope with the more severe conditions in which the LHC machine will operate after LS1 but also to attenuate sources of inefficiencies that would compromise the accuracy of the measurements. The BRM group is performing developments and studies in various fronts in the upgrade of BCM1F to ensure that the detector will continue to provide accurate, reliable and valuable information to the CMS experiment and the LHC machine.